

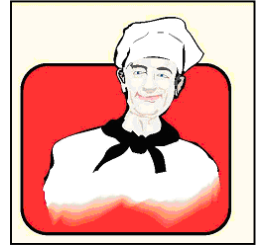

BOILING PAN (ELECTRICAL)

USER'S MANUAL

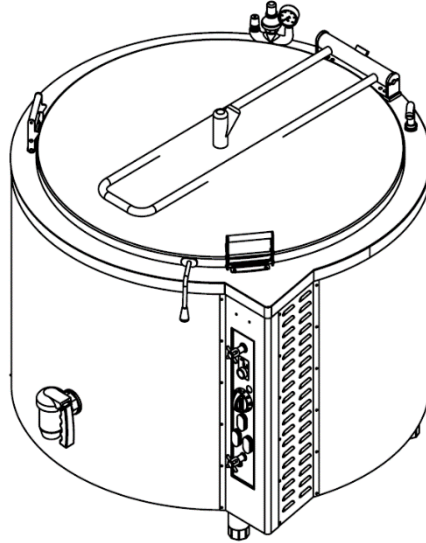
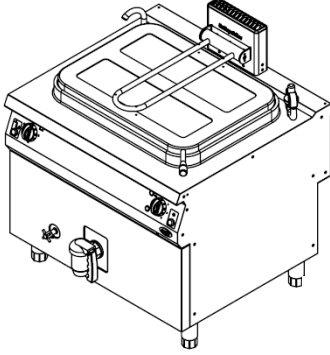

PRODUCTION YEAR:

SERIAL NO



MANUFACTURER : ÖZTİRYAKİLER MADENİ EŞYA SAN. VE TİC A.Ş.

PRODUCTION SITE : Cumhuriyet Mahallesi Hadımköy Yolu Caddesi No:8,1 No'lu Bağımsız Bölüm
Büyüçekmece İstanbul/TÜRKİYE

Phone : 0090 212 886 78 00 (8 Hat-Lines) Fax : 0090 212 886 66 29

Our website: www.oztiryakiler.com

e-mail: export@oztiryakiler.com.tr

TABLE OF CONTENTS

PAGE NR.	TOPICS
1	COVER PAGE
2	TABLE OF CONTENTS
3	INTRODUCTION
4	TECHNICAL DATA
5-6	MAIN DIMENSIONS
7	WARNING SIGNS
8	SAFETY DETAILS
9	TRANSPORTING AND MOVING
10	INSTALLATION OF THE APPLIANCE
11	CONTROL BOARDS
12-13	OPERATION OF THE APPLIANCE
14	CLEAN-UP AND MAINTENANCE
15	TERMS OF WARRANTY



CAUTION

This appliance should only be used in facilities where relevant standards, laws and safety requirements are complied with

INTRODUCTION

Dear User,

Thank you for purchasing our appliance and for your reliance upon our company. Our appliances are used in professional kitchens in 110 countries.

Our appliances are produced in compliance with international standards. Important notice: Please read and ensure that the users read this user's manual in order to achieve the desired performance in line with your expectations and to use your appliance for long years. Please take the warnings mentioned above into consideration before calling for service...

⚠ Please read and ensure that your operation personnel also reads this user's manual care fully before installing and using the appliance. If the appliance is operated without reading the user's manual, the appliance will not be covered by the warranty.

⚠ The manual containing information about installation, usage and maintenance of our product you purchased should be read carefully. Please ensure that power supply connections to the appliance are already installed by qualified personnel according to local legislation, before our authorized service personnel arrives for the installation of the appliance.

⚠ If you are confused or you don't have enough information please get in touch with authorized service by phone.



⚠ Please keep in mind that, if the service personnel is delayed at your site, related expenses and delay costs will be charged to you on hourly basis.

⚠ We hope that you will get the best performance from our product...

TECHNICAL DATA

YOUR PRODUCT'S TYPE	OTEI 60	OTEI 80	OTEI 100	OTEI 150	OTEI 200	OTEI 250 OTEIR 250	OTEI 300	OTEI 400	OTEI 500
MAIN DIMENSIONS (mm)	700X700X850	800X900X850	800X900X850	800X900X850	1000X900X850	OTEI 250 1000X900X850 OTEIR 250 1000X1100X850	1100X896	1100X1038	Ø1300X966
TOTAL ELECTRICAL INPUT (kW)	9	9	18	18	27	27	27	36	45
POWER SUPPLY VOLTAGE (V)	380-400(3NPE) / 220-240 (3 PE)	380-400(3NPE) / 220-240 (3 PE)	380-400(3NPE) / 220-240 (3 PE)	380-400(3NPE) / 220-240 (3 PE)	380-400(3NPE) / 220-240 (3 PE)	380-400(3NPE) / 220-240 (3 PE)	380-400(3NPE) / 220-240 (3 PE)	380-400(3NPE) / 220-240 (3 PE)	380-400(3NPE) / 220-240 (3 PE)
WORKING FREQUENCY (Hz)	50-60	50-60	50-60	50-60	50-60	50-60	50-60	50-60	50-60
WATER INLET CONNECTION	1/2" R	1/2" R	1/2" R	1/2" R	1/2" R	1/2" R	1/2" R	1/2" R	1/2" R
SUPPLY CABLE (H07 RNF)	5X4	5X4	5X4	5X4	5X6	5X6	5X6	5X6	5X6
CAPACITY (LITERS)	60	80	100	150	200	250	250	250	250
MAXIMUM SLOPE	5°	5°	5°	5°	5°	5°	5°	5°	5°
CLASS	1	1	1	1	1	1	1	1	1
PROTECTION CLASS	IP 21	IP 21	IP 21	IP 21	IP 21	IP 21	IP 21	IP 21	IP 21

MAIN DIMENSIONS

OTEI 250

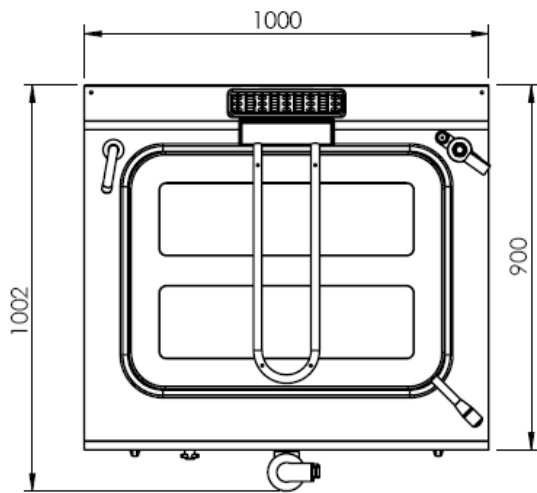
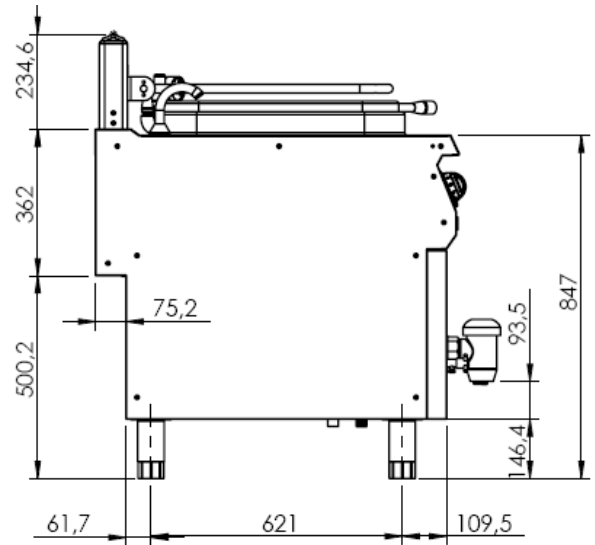
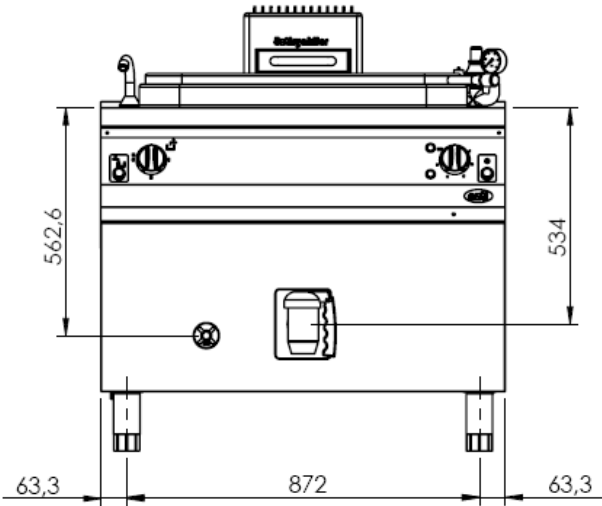

MAIN DIMENSIONS

OTEI 500

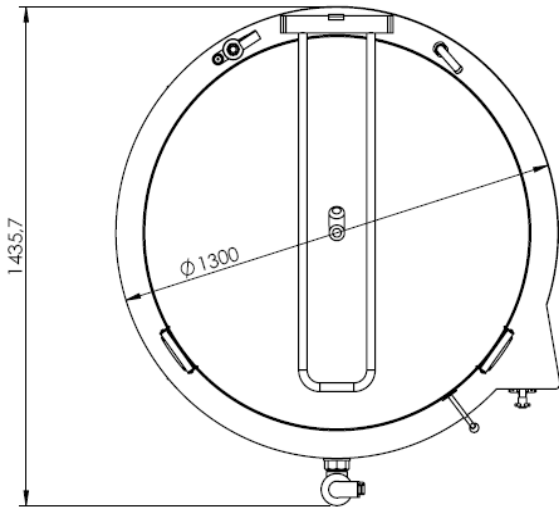
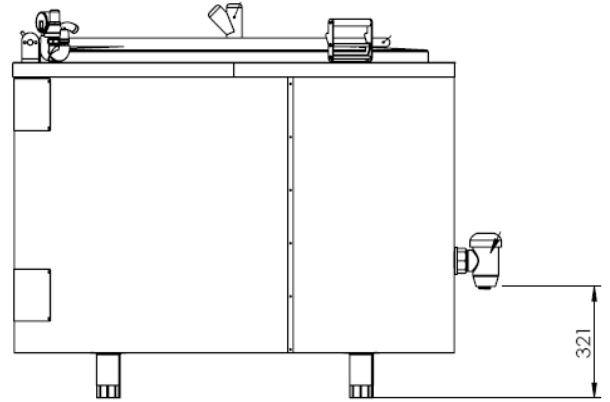
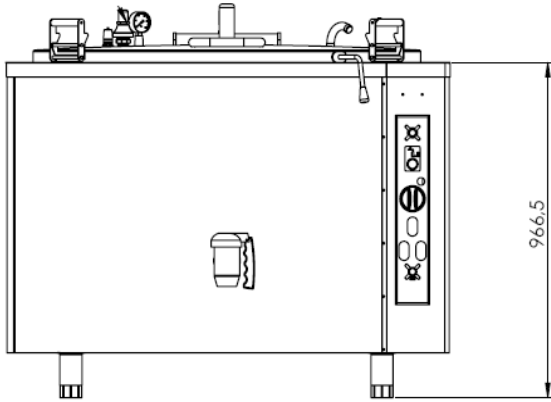

WARNING SIGNS



POWER NETWORK GROUNDING

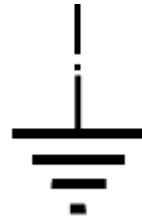

PE

GROUNDING



POWER



OVERHEAT

POWER SUPPLY CONNECTIONS
380/400 V 3 NPE - 50/60 Hz
220/240 V 3 PE - 50/60 Hz
SUPPLY CONNECTION: TRIPHASE
GROUNDED
FREQUENCY : 50-60 Hz

SAFETY DETAILS

☞ The appliance should only be operated under a chimney hood.

☞ Any kind of flammable solid and liquid material (cloths, alcohol and derivatives, petrochemical products, wooden and plastic materials, cutting blocks, curtains etc.) should never be held near the appliance.

☞ Use can use this appliance simultaneously together with other products of ours.

☞ Do not clean up the appliance with pressure water

☞ This appliance should be installed in line with effective regulations and only be operated in well ventilated places. Please refer to the instructions before installing and operating the appliance.

☞ This appliance is designed for industrial use and should only be operated by personnel trained on the appliance.

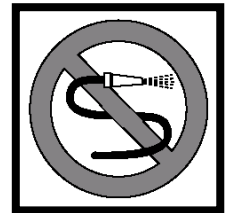

TRANSPORTING AND MOVING

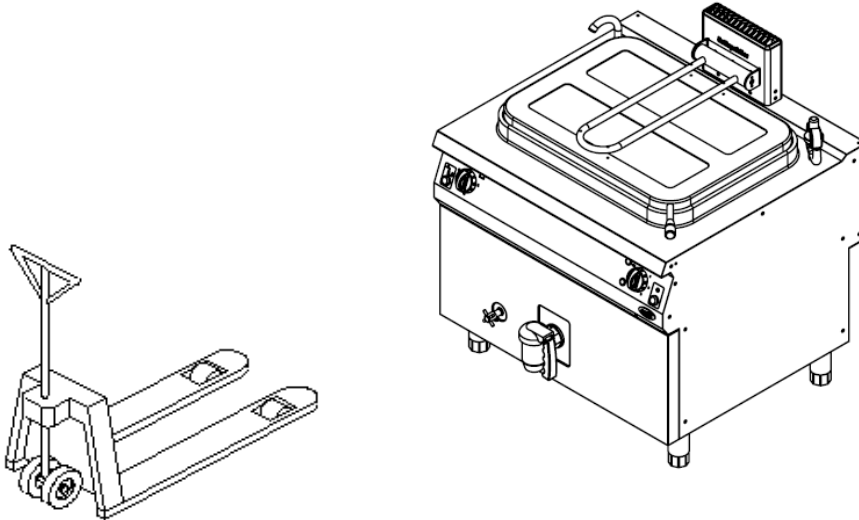

CHANGING THE LOCATION;
Machines installed by an authorized
service **CANNOT BE MOVED**
ELSEWHERE, ITS POWER SUPPLY CABLES
CANNOT BE EXTENDED OR REPLACED except
by an authorized service.

- ☞ **The device should be placed vertically on a palette with man power.**
- ☞ **Feet of the fork lift should be placed under the appliance.**
- ☞ **If the transported distance is far, the machine should be moved slowly and the appliance should be fixed on palette or supported in order to prevent jolt.**
- ☞ **Do not hit or drop the product when moving.**

INSTALLATION OF THE APPLIANCE

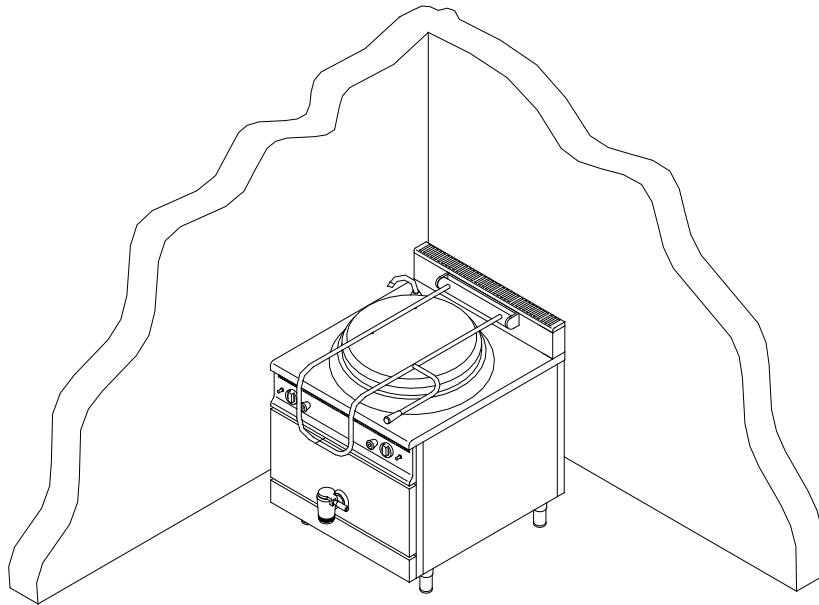

If this appliance located near to any wall, separation, kitchen furniture, decorative coating etc. the distance in between should be min. 20 cm. and if those are coated with fireproof heat insulating material, the distance should be min.5 cm. It is strongly recommended that fire safety protection instructions are observed.



All of the items mentioned below in connection with the installation of the appliance should be carried out by authorized service personnel.

- ⚠ Feet of the device should be adjustable and the device should be ensured to operate in a leveled position.
- ⚠ Power supply connection of the appliance should be checked by an eligible electrician, and it should be connected to a fuse at a maximum height of 170 cm.
- ⚠ Power supply connection should be made using a 30 mA current leakage fuse as a protection against current leakage danger.
- ⚠ Power installation to be used should be grounded by connecting it to a grounding bar at the nearest panel.

CONTROL BOARDS

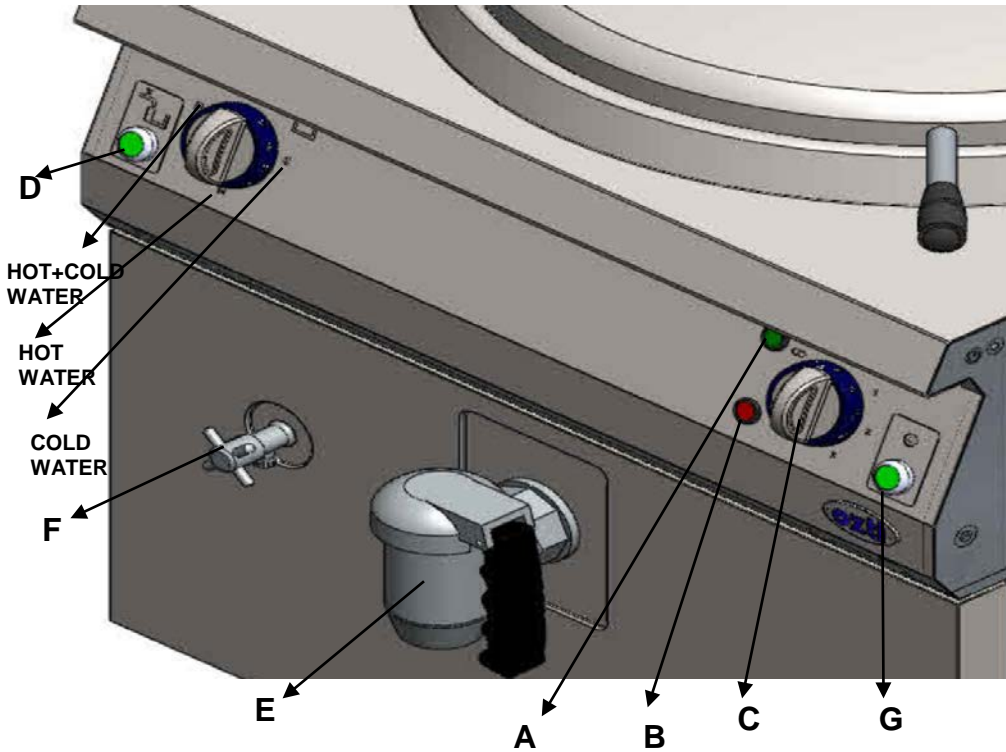

OTEI 500

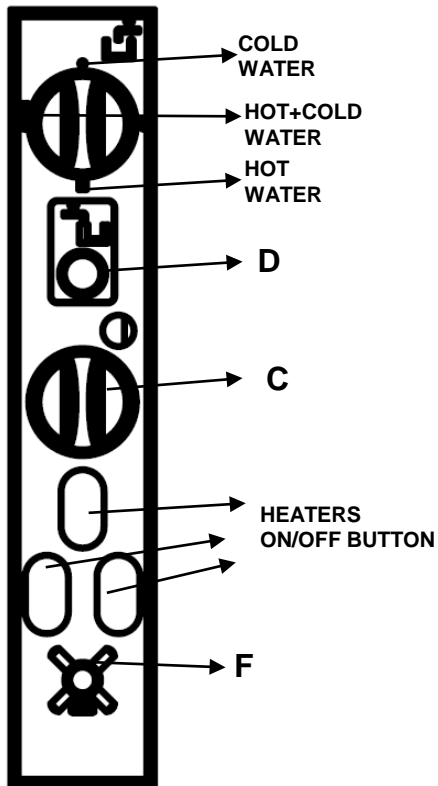

- A : APPLIANCE ON LAMP
- B : WARNING LAMP
- C : TERMOREGULATOR SWITCH
- D : WATER TAP BUTTON (FOR INNER WALL)
- E : FOOD EVACUATION TAP
- F : WATER LEVEL TAP (FOR INDIRECT MODELS)
- G : ON-OFF BUTTON
- H : MANOMETER
- K : 0,5 BAR SAFETY VALVE
- L : MANUEL SAFETY VALVE

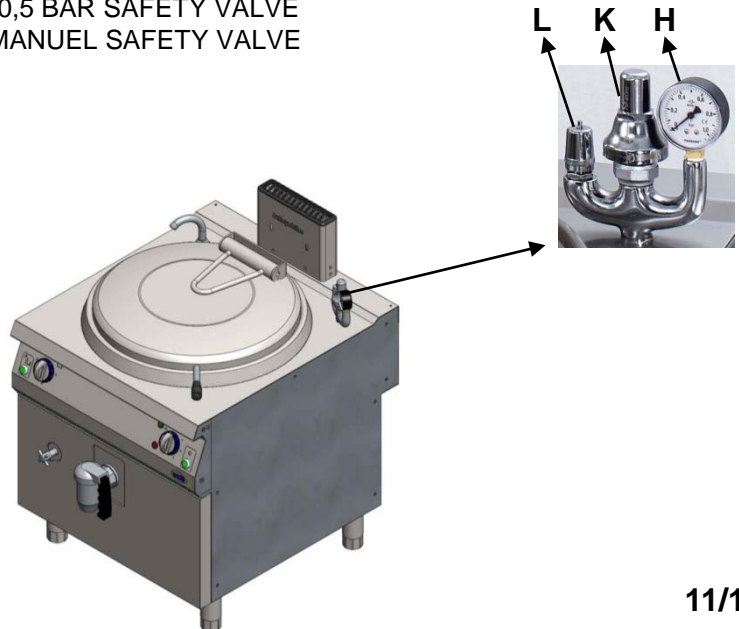

OPERATION OF THE APPLIANCE

1. Boiling pan is used in kitchens of restaurants, fast food stands, canteens, hospitals in order to cook.
2. Before initial use of the appliance, the outer surface should be wiped with a cloth soaked in warm water and soap.

NOTE: Do not use except purpose of use. The appliance should be operated by qualified personnel knowing safety terms and technical specifications and who has read the instruction manual.



CAUTION !
NEVER OPERATE YOUR appliance
WITHOUT GROUND CONNECTION.

WHAT TO DO BEFORE STARTING THE DEVICE

a. Inner walls water level:

In indirect models, inner wall water should be checked whether the water level is sufficient. This control is done by opening water level tap (F). If water flows from water level tap (F) the water level is sufficient. Tap is left open after the water flow diminishes, so that excess water is removed. After that you should close the level tap. And the appliances is ready to work.

b. Pressure indicator group

Pressure indicator group is a pressure safety group which keeps the vapor pressure created at inner walls from exceeding 0.5 bar level. Supplying water without calc is very important to prevent the group from being covered with calc and being clogged. (Fitting a purification system to water installation is highly recommended. If the group is clogged due to calc formed, the pressure may raise severely that could deform inner walls). The manometer (L) shows the pressure of the inner wall. A red line is drawn at the 0.5 bar scale. This line indicates the safety level. When this level is exceeded, 0.5 bar safety valve (K) is actuated preventing the pressure from exceeding 0.5 bar level. If for any reason 0.5 bar safety valve (K) is not actuated and the pressure continues to raise, then the pin on the manual safety valve (L) should be pressed, in order to eliminate excess pressure. If this is also clogged due to calc formation, not being able to stop overpressure, then please turn the appliance off and call the authorized service.

OPERATION OF THE DEVICE:

- 1-) Push the on-off button (G) "ON". And turn Termoregulator Switch (C) to desired position (0-1-2-3-4-5- ∞) Green warning lamp (A) on the appliance will light.
- 2-) When the device is operated food to be cooked should had been placed into the pan. Do not run the device when the device is empty. After the cooking is finished the device is turned off.
- 3-) Set Termoregulator Switch (C) to '0' off position and On-Off Button (G) to off position to shut down the device.
- 4-) Cooked food is transferred through the food evacuation tap at the front part of the device, into a container with suitable size. Please be careful when evacuating the food inside, it may be very hot.
- 5-) After evacuating is completed inside of the pan should be cleaned.



It is recommended to operate the appliance between temperatures of +5°C +40°C and in ambient humidity of maximum 65%.

OPERATION OF THE APPLIANCE



CAUTION! : The appliances should be installed and operated as described in this user's manual. If any failure is encountered please contact our nearest authorized service dealer.

WHEN THE APPLIANCES HAS A FAILURE ONLY AUTHORIZED SERVICE DEALERS ARE ALLOWED TO HANDLE THE APPLIANCES. IF ANY PERSON OTHER THAN ONLY AUTHORIZED SERVICE DEALERS HANDLE THE APPLIANCES, IT WILL NOT BE COVERED BY THE WARRANTY.

NEVER ALLOW PEOPLE WHO ARE NOT AUTHORIZED TO HANDLE THE APPLIANCES. OTHERWISE PRODUCER COMPANY WILL NOT BE RESPONSIBLE FOR THE CONSEQUENCES. DURING MAINTENANCE SERVICE OUR AUTHORIZED SERVICE DEALERS SHOULD NOT BE PROPOSED TO USE NON-ORIGINAL SPARE PARTS FOR WHATSOEVER. INSTALLING ANY NON-ORIGINAL SPARE PART TO THE APPLIANCE LEAVES THE APPLIANCE OUT OF WARRANTY COVERAGE.



CLEAN-UP AND MAINTENANCE

1. CLEAN-UP:

Turn the appliance off after daily use. Water basin should be drained off through the evacuation tap for clean-up and every surface of the appliance should be completely cleaned up with sponge and liquid detergent. Do not use CHEMICAL CLEANING AGENTS like hydrochloric acid or abrasive cleaning agents.

2. MAINTENANCE:

Periodic maintenance should be carried out by a technician. It is recommended to carry out maintenance at least every 6 months, depending on the frequency of use. Periodic maintenance conducted by authorized service personnel of ours is charged, even the guarantee period has not expired.

LIFE OF USE

appliances life of use is 10 year if it is used under recommended conditions.

TERMS OF WARRANTY

- 1- Documents without sales date, factory and sales company approval on, are not valid. In order to benefit from the warranty, warranty document should be presented.
- 2- If the appliance is installed and operated following the instructions in the installation, maintenance and user's manual, it is warranted for failures sourcing from materials and workmanship .
- 3- The failures within the scope of warranty, how and where these will be eliminated, and the way and place of maintenance is determined by
- 4- The warranty is only valid provided that the warranty terms and the instructions in the installation, maintenance and user's manual are fully complied with. The warranty is only valid for the warranted appliance, and no other right or compensation for some other thing may be claimed.
- 5- If the information about the kind and the type of the appliance, serial numbers printed on the warranty document are scraped, rubbed or changed, then the warranty is not valid.
- 6- The warranty covers only maintenance and repairing of material or workmanship failure within the valid warranty period. Failures and parts within the scope of the warranty are repaired and replaced without any charge. Replaced parts belong to
- 7- The failures occurring in the appliance may only be handled by service personnel authorized by If people who are not authorized handle the appliance, it will not be covered by the warranty.
- 8- Installation should be carried out by authorized service personnel and the service should be informed about the location change of the appliance.
- 9- When any failure occurs during operation, authorized service dealer should be contacted.
- 10- Warranty does not cover failures and damages resulting from loading, unloading and shipping, which are outside the responsibility of Similarly, failures and damages resulting from external factors are not covered.